

MAXIMATOR®

HIGH PRESSURE
TECHNOLOGY
HYDRAULICS
PNEUMATICS
TESTING
EQUIPMENT



MAXIMATOR GmbH

Air Amplifiers



MAXIMATOR PLV series Air Amplifiers are suitable for the compression of pressurised air or nitrogen. The units are capable of increasing normal pressures of 4 bar or 6 bar to the desired final pressures. The PLV Air Amplifiers are operated with normal shop air and are provided with a variety of amplification ratios.

All PLV Air Amplifiers can be supplied with an air control unit comprising a filter, pressure regulator with pressure gauge and an air shut-off valve.

The desired operating pressure can be preset by means of the air control unit in correspondence with the different pressure ratios.

We can offer you a choice between a standard PLV Air Amplifier Station or a customised solution.

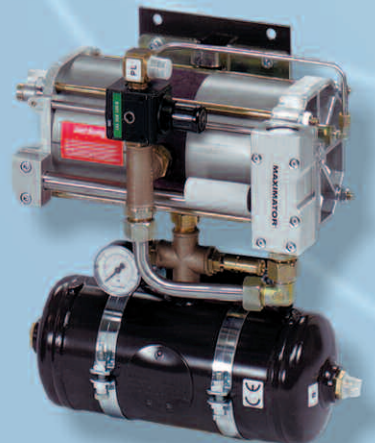
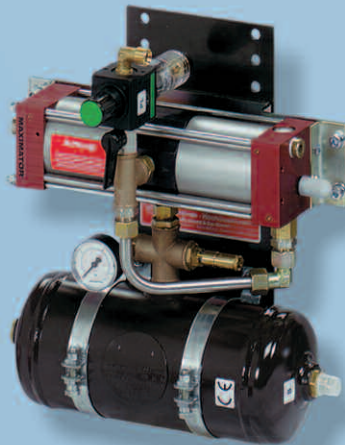
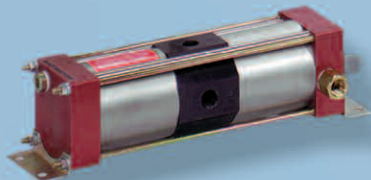
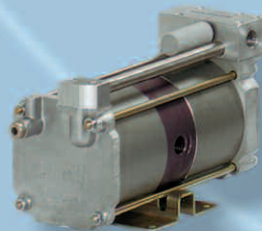
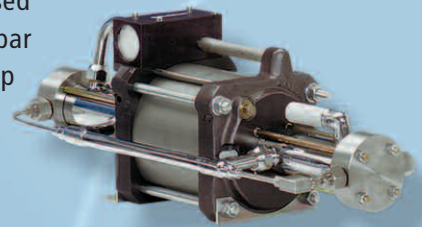

Burner cleaning

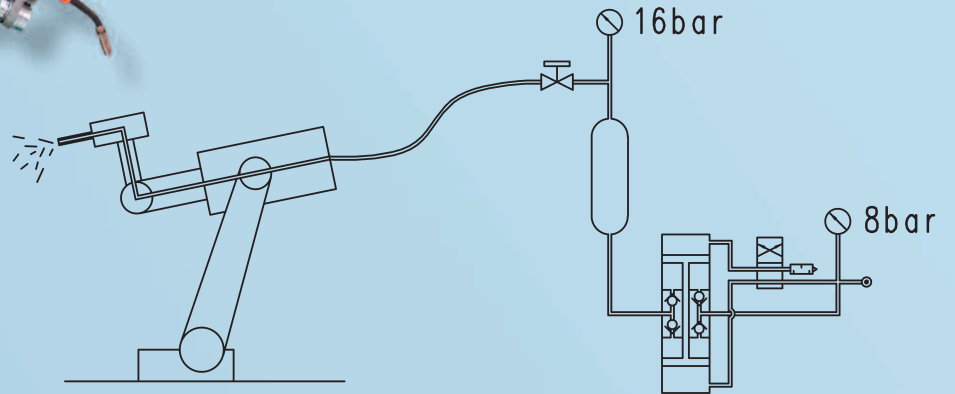
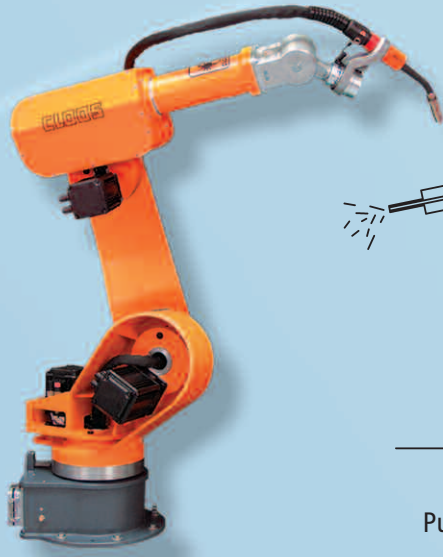

Purging of impurities by means of 16-bar pressure shocks.

Automotive sector

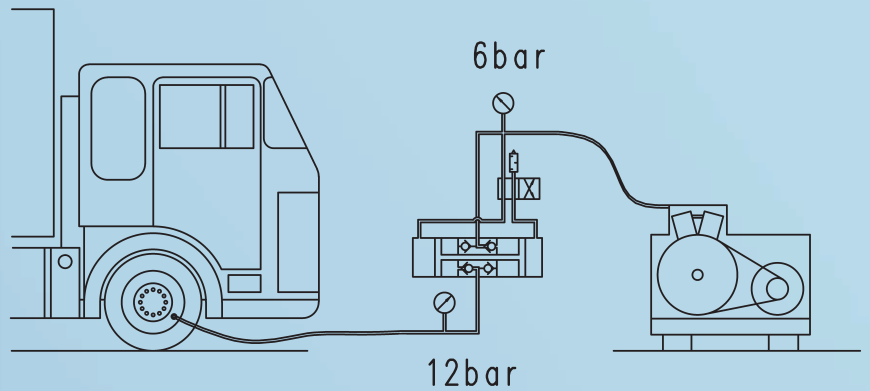

Filling of tyres with 16-bar pressure.

Cleaning of varnishing systems (pigging)

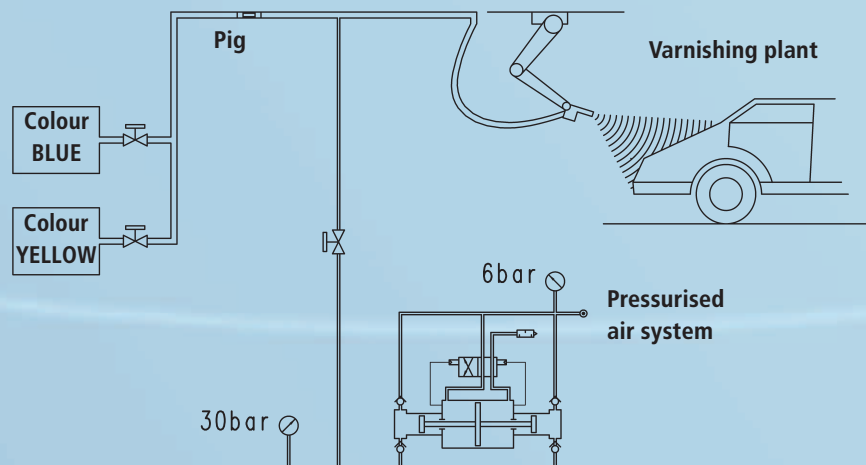

The dyes are forced back into the tanks by means of a pressurised air-driven pig.

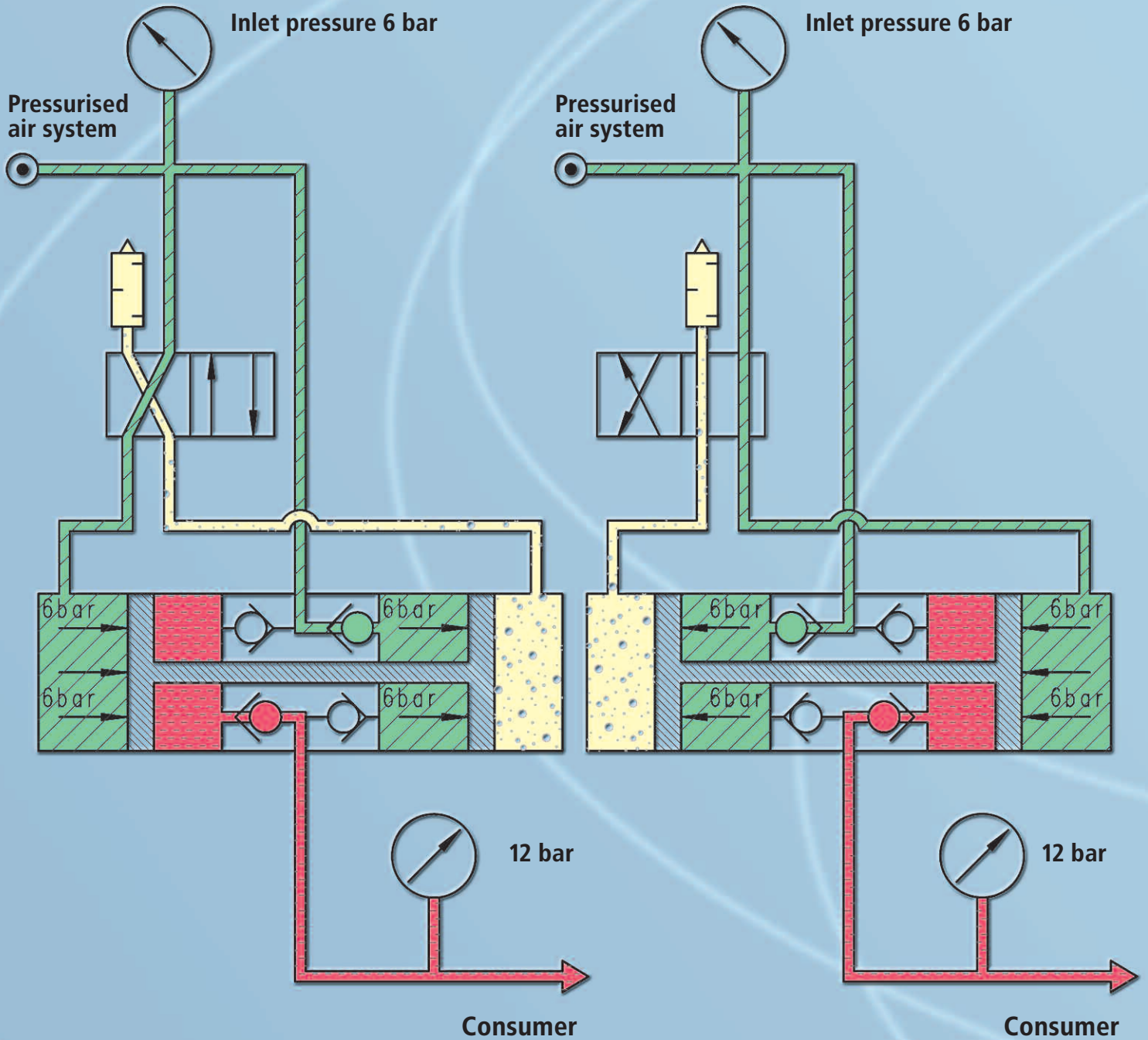

The compressed air from the standard air system is compressed to the desired higher final pressure. This is a simple, safe and economic mode of operation. Thus, expenditures for an in-house high-pressure system or a separate decentralised compressor plant can be saved.

The benefits of this design are:

- Selected pressure boosting upstream of individual consumers.
- Zero energy consumption after final pressure is attained.
- No electrical installations are required.

Air Amplifier GPLV 2 1200 l_N/min*

MAXIMATOR®

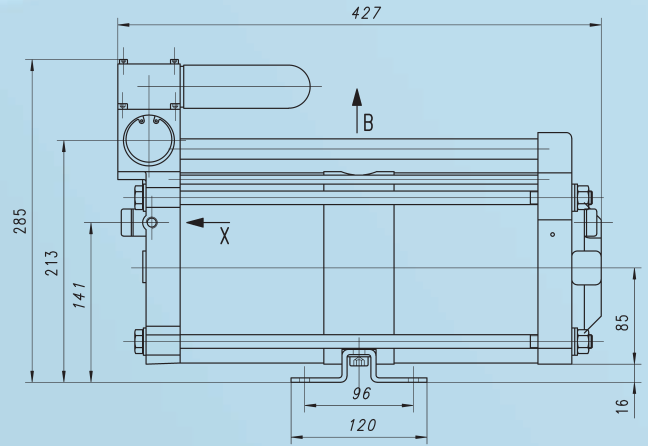

The benefits of the GPLV2 design are:

- Selected pressure boosting upstream of individual consumers.
- Zero energy consumption after final pressure is attained.
- No electrical installations are required, i.e. suitable for use in explosion-proof areas

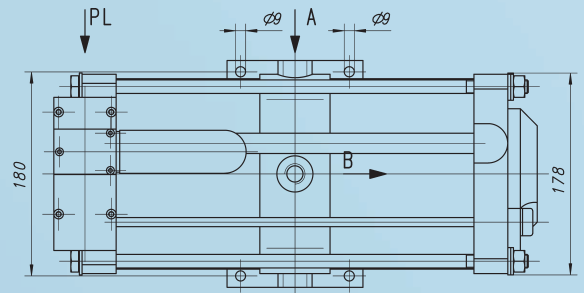

The benefits of the GPLV 2-Station are:

- Pressure pulsation rates lower than compared to units without air receivers.
- Any air consumption peaks are compensated by the air receiver volume reserve.
- Operating pressure can be adjusted by means of a reducing regulator.

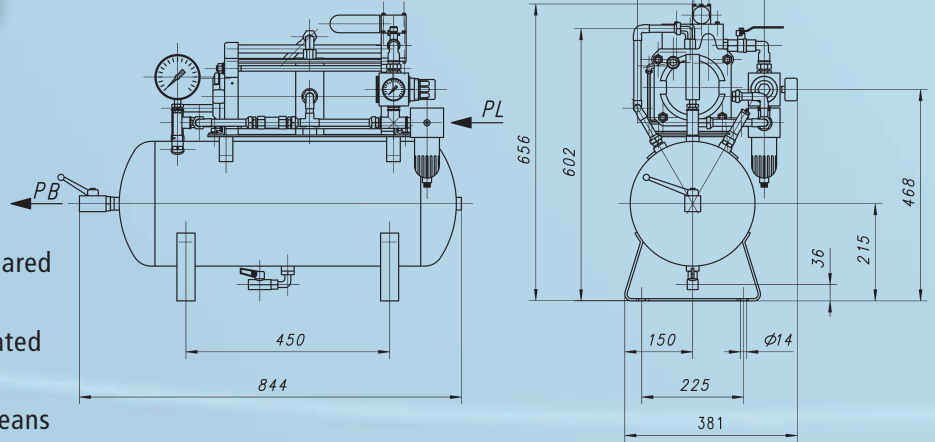

Technical data:

Type	GPLV 2
Pressure ratio (i)	1:2
Air drive pressure (p _i) in bar	1 – 10
Max. discharge pressure (p _e) in bar	20 (16) ¹⁾
Max. noise level	79 dB(A)
Max. operating temperature (T) in °C	60
Air drive connection	BSP 3/4"
Inlet connection	BSP 1/2"
Outlet connection	BSP 1/2"
Net weight in kg	20.5
(Station) net weight in kg	49.0

* at inlet pressure 6 bar and operating pressure 8 bar and 50 % operating time

1) Limited by pressure vessel rating

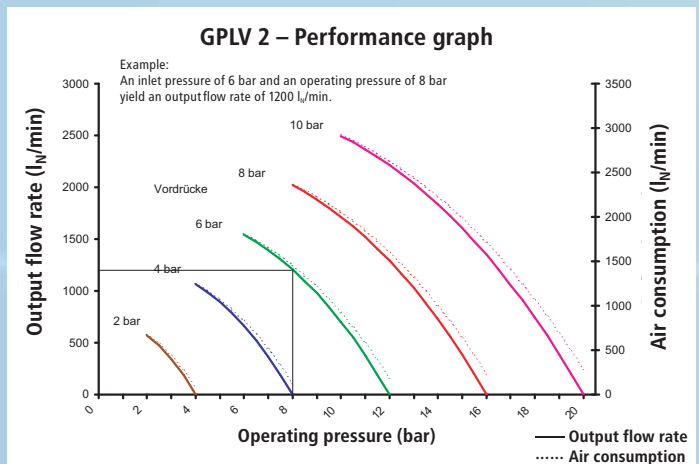

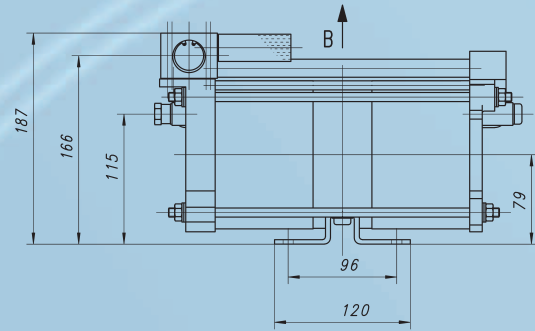
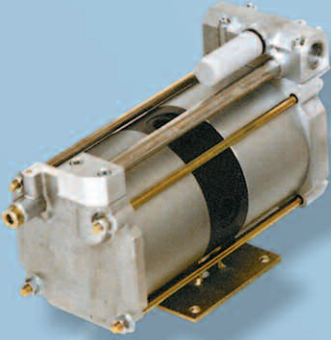

The benefits of the SPLV2 design are:

- Selected pressure boosting upstream of individual consumers.
- Zero energy consumption after final pressure is attained.
- No electrical installations are required, i.e. suitable for use in explosion-proof areas.

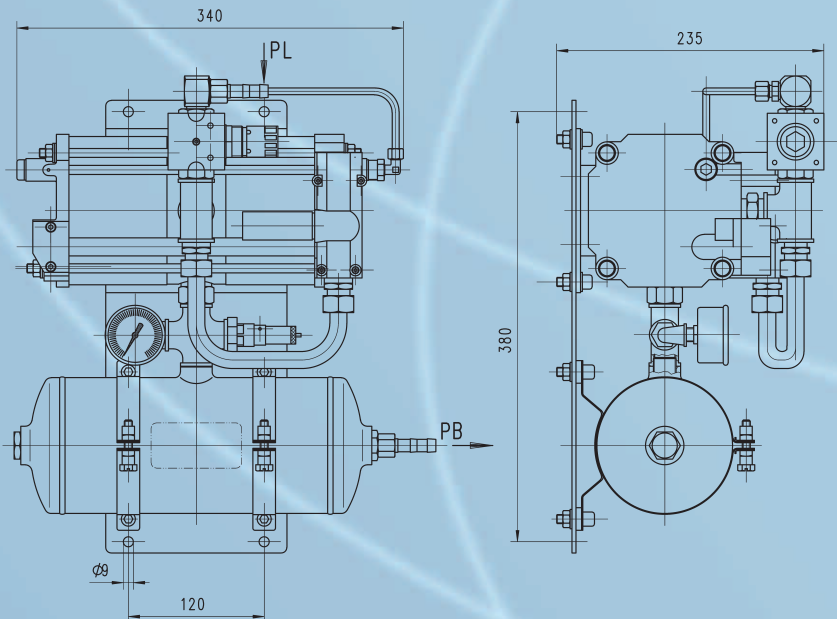
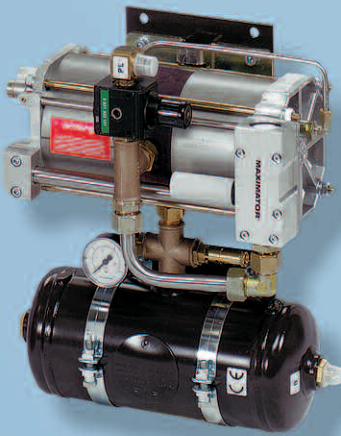
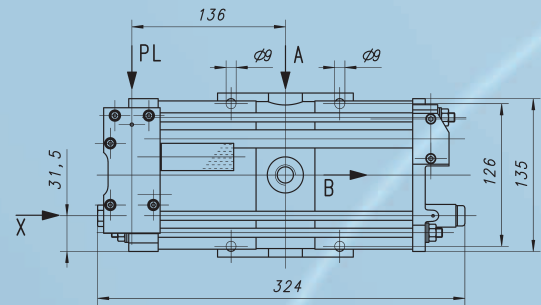

The benefits of the SPLV 2-Station are:

- Pressure pulsation rates lower than compared to units without air receiver.
- Any air consumption peaks are compensated by the air receiver volume reserve.
- Operating pressure can be adjusted by means of a reducing regulator.

Technical data:

Type	SPLV 2
Pressure ratio (i)	1:2
Air drive pressure (p _i) in bar	1 – 10
Max. discharge pressure (p _e) in bar	20 (16) ¹⁾
Max. noise level	79 dB(A)
Max. operating temperature (T) in °C	60
Air drive connection	BSP 1/2"
Inlet connection	BSP 1/2"
Outlet connection	BSP 1/2"
Net weight in kg	8.5
(Station) net weight in kg	16.0

* at inlet pressure 6 bar and operating pressure 8 bar and 50 % operating time

1) Limited by pressure vessel rating

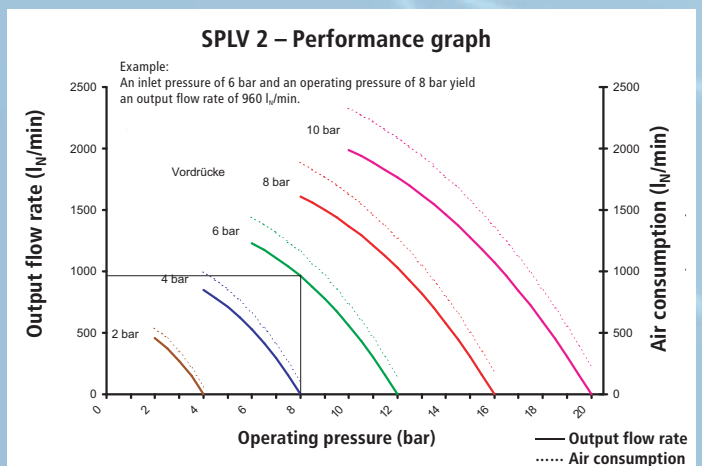

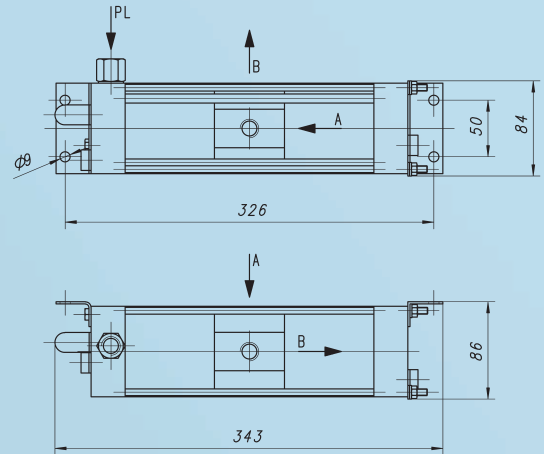
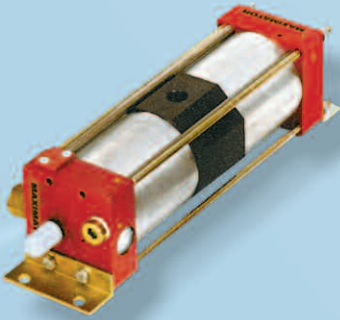

The benefits of the MPLV 2 design are:

- Selected pressure boosting upstream of individual consumers.
- Zero energy consumption after final pressure is attained.
- No electrical installations are required, i.e. suitable for use in explosion-proof areas.

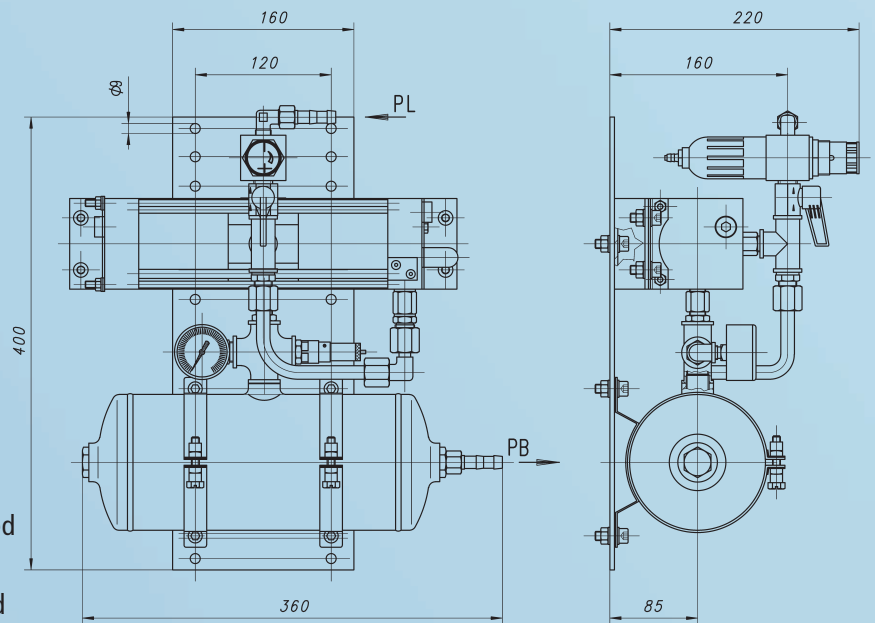
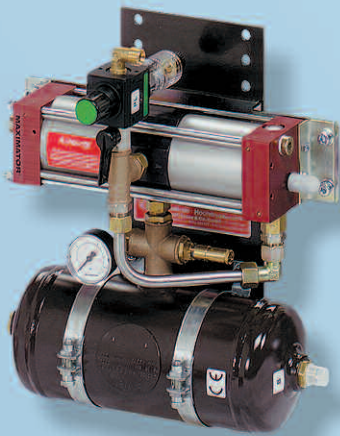

The benefits of the MPLV 2-Station are:

- Pressure pulsation rates lower than compared to units without air receiver
- Any air consumption peaks are compensated by the air receiver volume reserve.
- Operating pressure can be adjusted by means of a reducing regulator.

Technical data:

Type	MPLV 2
Pressure ratio (i)	1:2
Air drive pressure (p _i) in bar	1 – 10
Max. discharge pressure (p _e) in bar	20 (16) ¹
Max. noise level	79 dB(A)
Max. operating temperature (T) in °C	60
Air drive connection	BSP 3/8"
Inlet connection	BSP 3/8"
Outlet connection	BSP 3/8"
Net weight in kg	3.3
(Station) net weight in kg	13.0

* at inlet pressure 6 bar and operating pressure 8 bar and 50 % operating time

1) Limited by pressure vessel rating

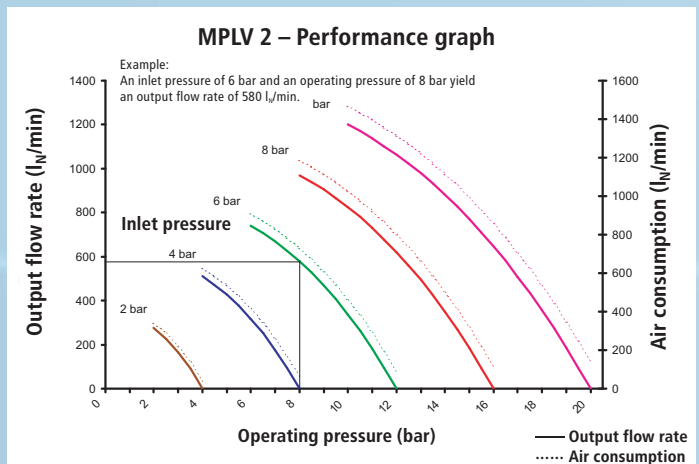

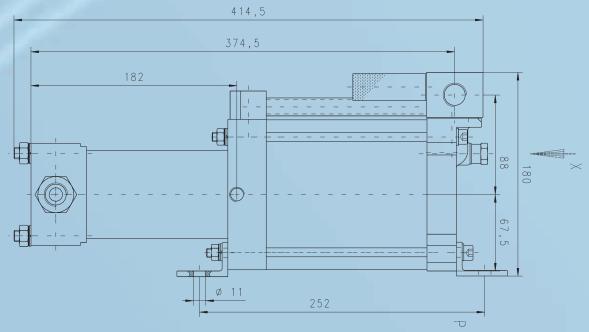
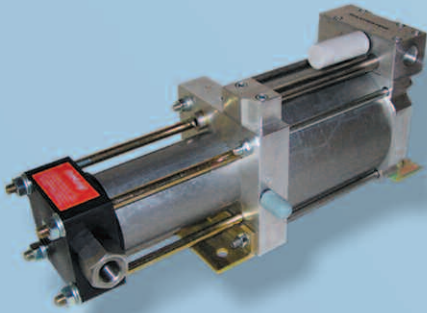

The benefits of the SPLV 3 design are:

- Selected pressure boosting upstream of individual consumers.
- Zero energy consumption after final pressure is attained.
- No electrical installations are required, i.e. suitable for use in explosion-proof areas

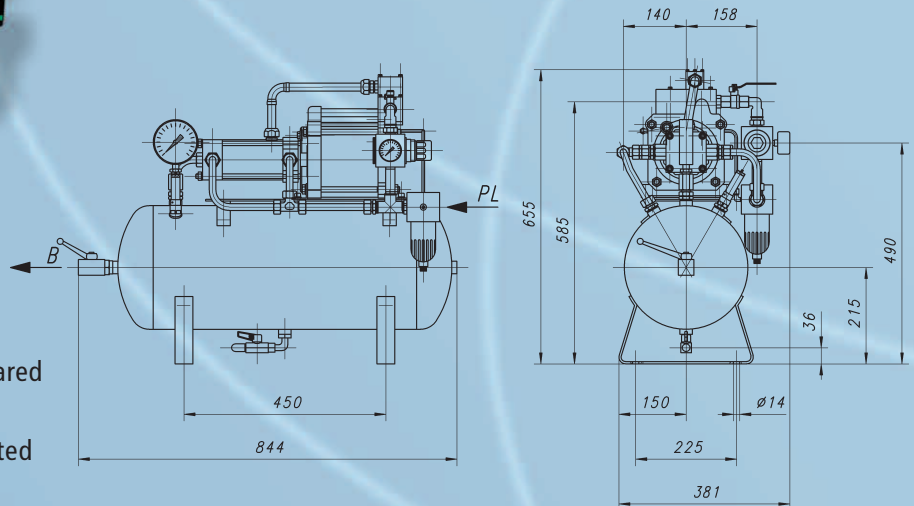
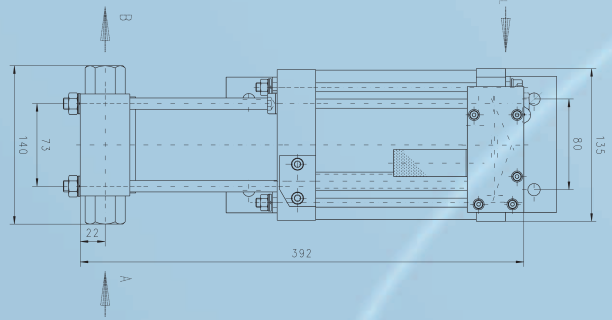

The benefits of the SPLV 3-Station are:

- Pressure pulsation rates lower than compared to units without air receivers.
- Any air consumption peaks are compensated by the air receiver volume reserve.
- Operating pressure can be adjusted by means of a reducing regulator.

Technical data:

Type	SPLV 3
Pressure ratio (i)	1:3,2
Air drive pressure (p _i) in bar	1 – 10
Max. discharge pressure (p _e) in bar	32 (16) ¹
Max. noise level	79 dB(A)
Max. operating temperature (T) in °C	60
Air drive connection	BSP 1/2"
Inlet connection	BSP 1/2"
Outlet connection	BSP 1/2"
Net weight in kg	8.5
(Station) net weight in kg	16.0

* at inlet pressure 6 bar and operating pressure 8 bar and 50 % operating time

1) Limited by pressure vessel rating

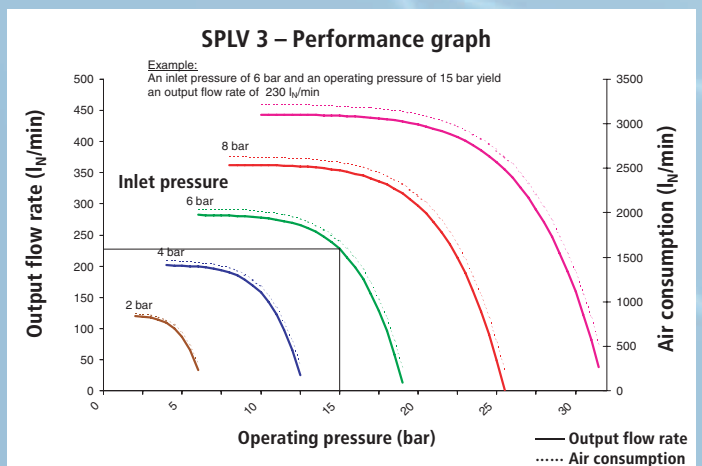

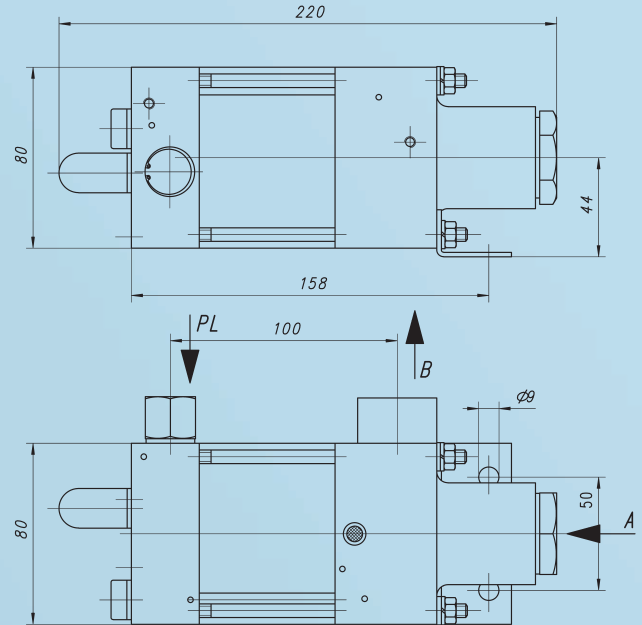
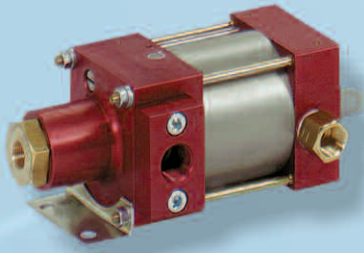

The benefits of the MPLV 4 design are:

- Selected pressure boosting upstream of individual consumers.
- Zero energy consumption after final pressure is attained.
- No electrical installations are required, i.e. suitable for use in explosion-proof areas.

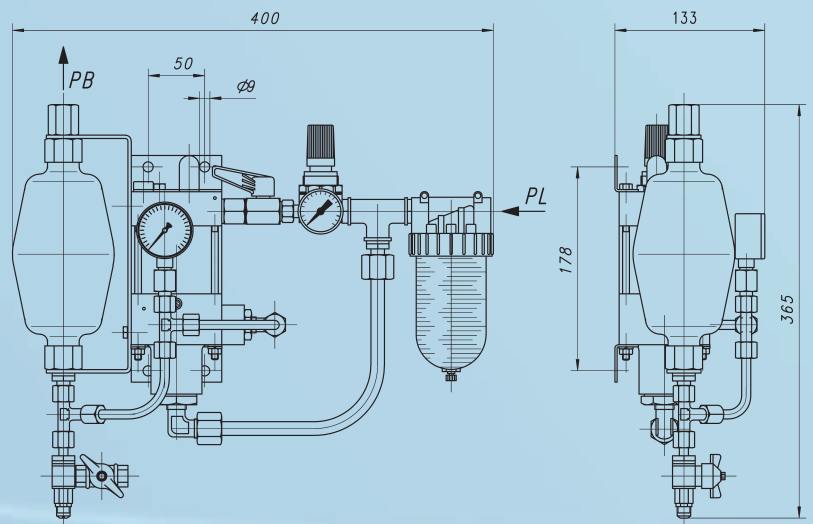

The benefits of the MPLV 4-Station are:

- Pressure pulsation rates lower than compared to units without air receiver.
- Any air consumption peaks are compensated by the air receiver volume reserve.
- Operating pressure can be adjusted by means of a reducing regulator.

Technical data:

Type	MPLV 4
Pressure ratio (i)	1:4
Air drive pressure (p _i) in bar	2 – 10
Max. discharge pressure (p _e) in bar	32 (16) ¹
Max. noise level	79 dB(A)
Max. operating temperature (T) in °C	60
Air drive connection	BSP 3/8"
Inlet connection	BSP 3/8"
Outlet connection	BSP 1/2"
Net weight in kg	2.2
(Station) net weight in kg	5.3

* at inlet pressure 6 bar and operating pressure 16 bar and 50 % operating time

1) Limited by pressure vessel rating

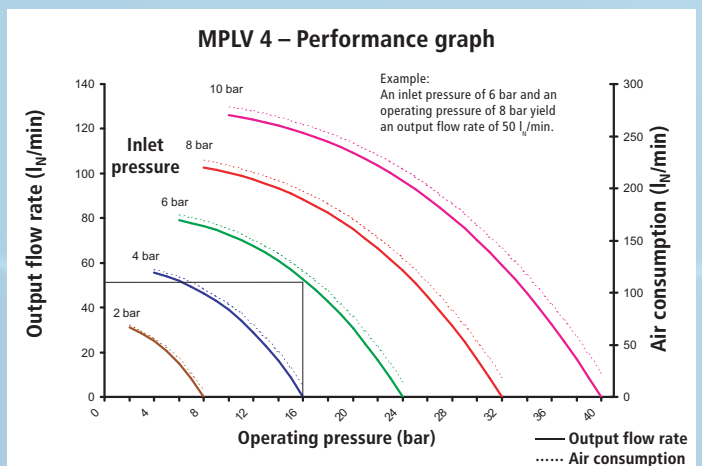

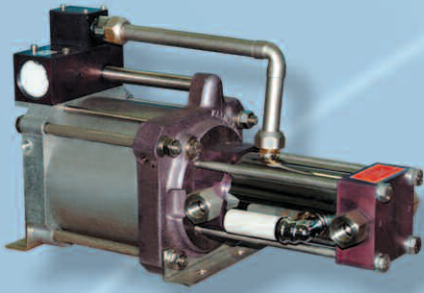

The benefits of the GPLV5 design are:

- Selected pressure boosting upstream of individual consumers.
- Zero energy consumption after final pressure is attained.
- No electrical installations are required, i.e. suitable for use in explosion-proof areas

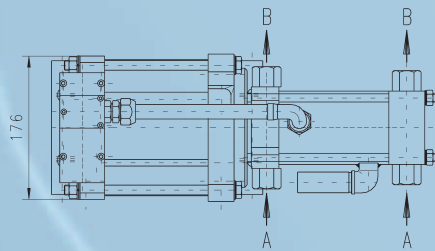
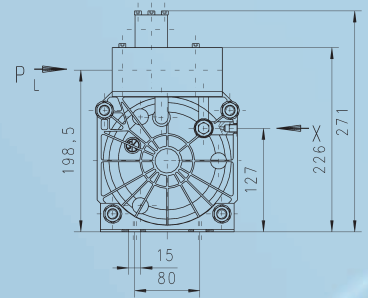
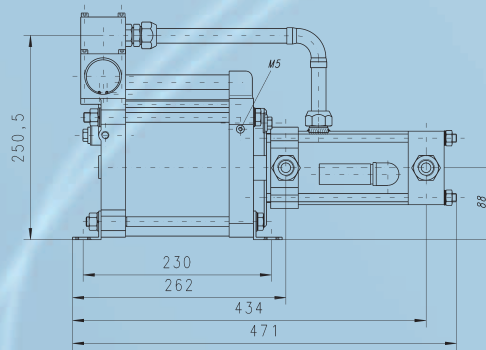

The benefits of the GPLV 5-Station are:

- Pressure pulsation rates lower than compared to units without air receivers.
- Any air consumption peaks are compensated by the air receiver volume reserve.
- Operating pressure can be adjusted by means of a reducing regulator.

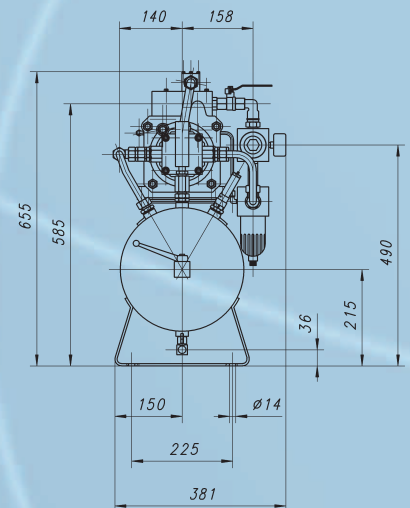
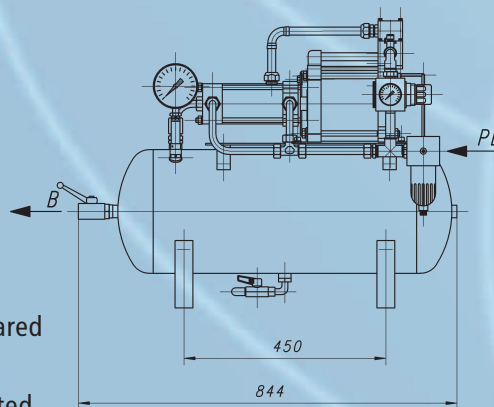

Technical data:

Type	GPLV 5
Pressure ratio (i)	1:5
Air drive pressure (p _i) in bar	1 – 10
Max. discharge pressure (p _b) ¹⁾ in bar	60 (40) ²⁾
Max. noise level	79 dB(A)
Max. operating temperature (T) in °C	60
Air drive connection	BSP 3/4"
Inlet connection	BSP 1/2"
Outlet connection	BSP 1/2"
Net weight in kg	20.5
(Station) net weight in kg	49.0

* at inlet pressure 6 bar and operating pressure 8 bar and 50 % operating time

- 1) Formula $5 \times p_L + p_A$ 2) Limited by pressure vessel rating

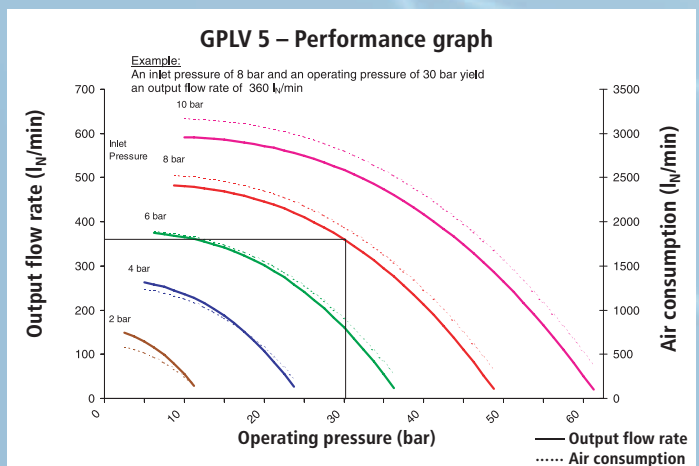

Pressure regulators

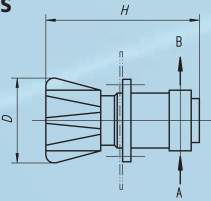

Control range bar	Inlet pressure bar	Medium	Connections	Material	Item N°
0.5-25	40	Air / N ₂	1/4" BSP	Brass	3300.3538
0.5-25	40	Air / N ₂	1/2" BSP	Brass	3300.3635
0.5-50	50	Air / N ₂	1/4" BSP	Brass	3300.5636
0.5-50	50	Air / N ₂	1/2" BSP	Brass	3300.5637

Air pilot switches

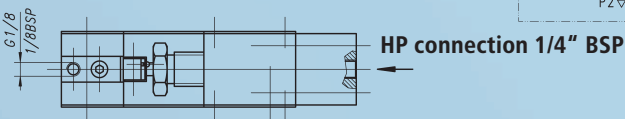
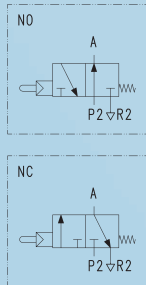
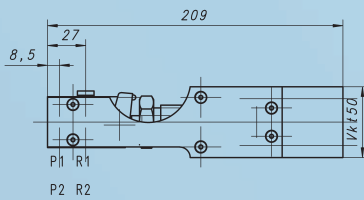

Adjustment range bar	NO Item N° (Normally open)	NC Item N° (Normally closed)
10-30	3630.1451	3630.1619
30-100	3630.1435	3630.1617

Safety relief valves

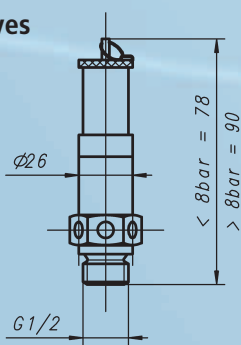

Relief pressure bar	Item N° 1/4" BSP	Item N° 1/2" BSP
5.0	3610.2587	3620.2515
6.0	3610.2589	3620.2690
8.0	3610.2592	3620.4214
16.0	3620.3033	3620.2695
40.0	3610.2594	3620.3688

Other relief pressures upon request.

All safety valves are accompanied by a TÜV testing authority certificate.

Pressure gauges

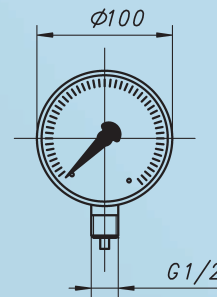

Measuring range bar	Item N°
0-10	3300.0142
0-16	3300.0143
0-25	3300.0144
0-40	3300.0145
0-60	3300.0146

Air control units

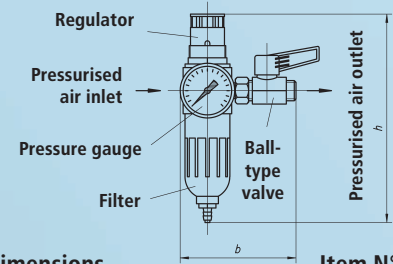

PLV type	Order	Dimensions H	Dimensions W	P _{LIN}	P _{L OUT}	Item N°
MPLV	C1	173	94	1/4" BSP	3/8" BSP	3300.0279
SPLV	C1.5	200	112	3/8" BSP	1/2" BSP	3300.0127
GPLV	C2	240	315	1/2" BSP	3/4" BSP	3300.0280

Pressurised-air receivers

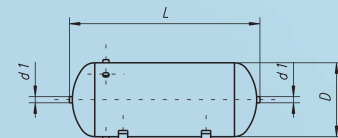

Allowed operating pressure bar	Volume capacity litres	L	Diam.	d1	Item N°
40	0.75	210	90	BSP 1/4"	3610.1636
16	3	315	125	BSP 1/2"	3630.0910
16	20	650	206	BSP 1/2"	3200.0129
16	40	750	276	BSP 1/2"	3300.0456
21	40	750	276	BSP 1/2"	3300.0457
40	40	750	276	BSP 1/2"	3300.3571
16	100	900	400	BSP1 1/2"	3300.1963

Pneumatic valves, electrical actuation

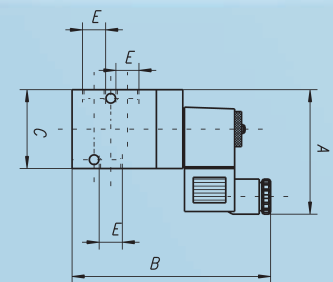
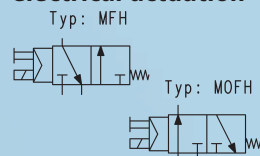

Type	Dimensions in mm					Item N°
	A	B	C	D	E	
MFH-3-1/8	71.0	113.0	45.0	26.0	BSP 1/8"	3300.0416
MOFH-3-1/8	71.0	113.0	45.0	26.0	BSP 1/8"	3300.2080
MFH-3-1/4	73.5	128.0	50.0	30.4	BSP 1/4"	3610.2304
MOFH-3-1/4	73.5	128.0	50.0	30.4	BSP 1/4"	3610.2411
MFH-3-1/2	88.5	167.0	80.0	52.0	BSP 1/2"	3300.1296
MOFH-3-1/2	88.5	167.0	80.0	52.0	BSP 1/2"	3300.2074
Solenoid valve coil	24 V DC					3610.2402
Solenoid valve coil	230 V AC					3610.2305

MAXIMATOR®

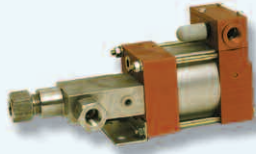

High-pressure pumps for oil, water, emulsions

- Minimum maintenance, explosion-proof
- Low energy consumption
- Max. operating pressures 5,500 bar



Test benches for pressure, bursting pressure and pulse tests

- Expansion hoses, tubing
- Valves, fittings, bolted unions
- Pressure gauges, pressure-operated switches
- Pressure transducers, vessels
- Special test benches



Gas boosters up to 1,500 bar

- For pressurising nitrogen, oxygen, noble gases
- Simple handling
- Explosion-proof due to pressurised air drive
- Max. operating pressures 1,500 bar



Gas assist systems

- Compressor stations with pneumatic, electrical or hydraulic drive
- Control modules with 1, 2 or 4 valves
- Compressor-control module combinations
- Pressurised air / N₂ up to max. 500 bar



High pressure valves, fittings and tubing

- Stainless steel components in excellent workmanship
- Temperature range - 250 °C to + 650 °C
- Max. operating pressures 10,500 bar

Your Representative:



MAXIMATOR GmbH

Factory

MAXIMATOR GmbH
Walkenrieder Str. 15
D-37449 Zorge / Germany
www.maximator.de

Telephone: ++49 55 86 / 80 30
Facsimile: ++49 55 86 / 8 03 30 40
eMail: info@maximator.de

All technical and dimensional information subject to change. All general Terms and Conditions of sale, including limitations of our liability, apply to all products and services sold.